

5700-C Weekly Lubrication Locations

Numbers in parentheses indicate number of grease points for each location

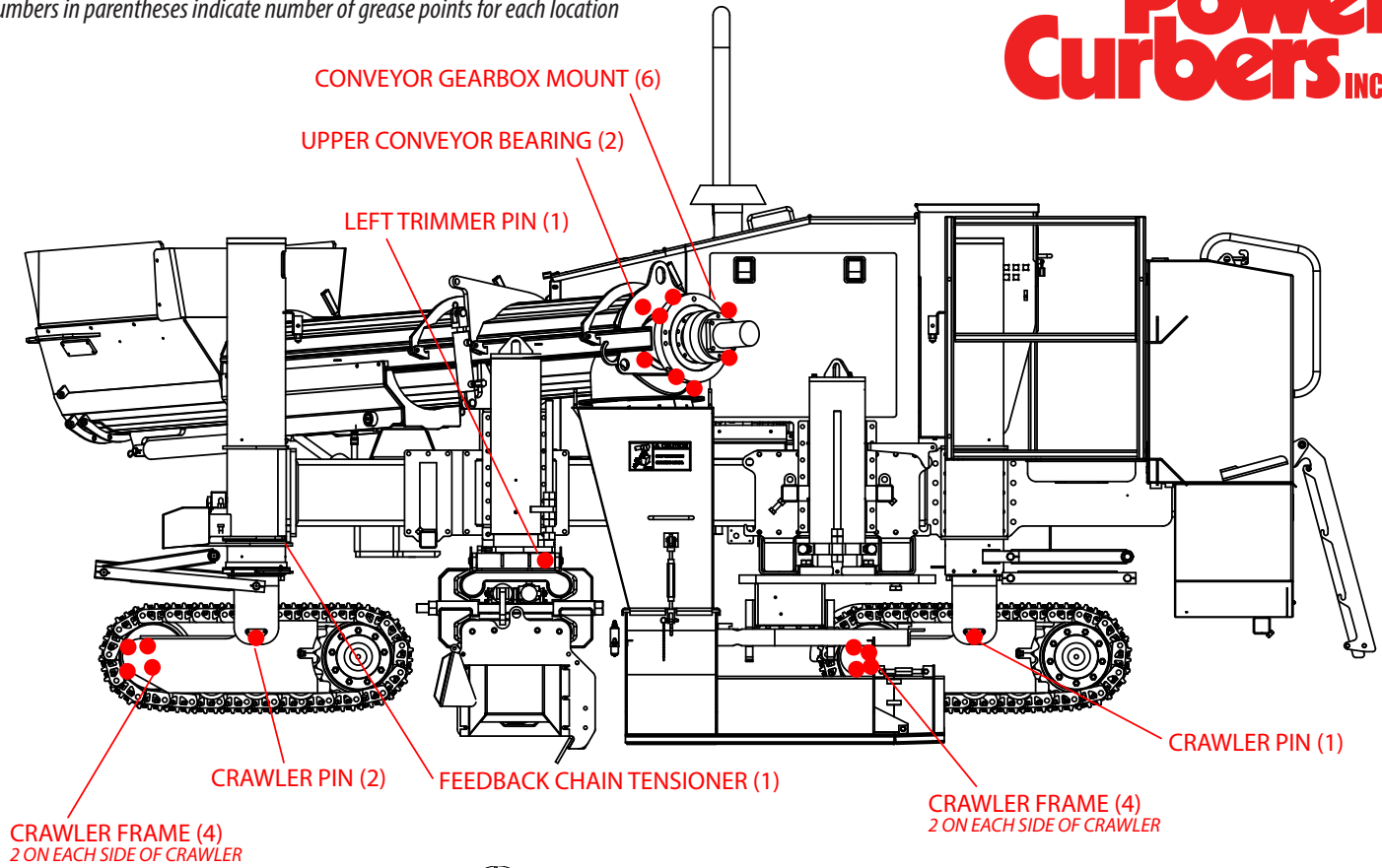

CRAWLER FRAME (4)
2 ON EACH SIDE OF CRAWLER

CRAWLER FRAME (4)
2 ON EACH SIDE OF CRAWLER

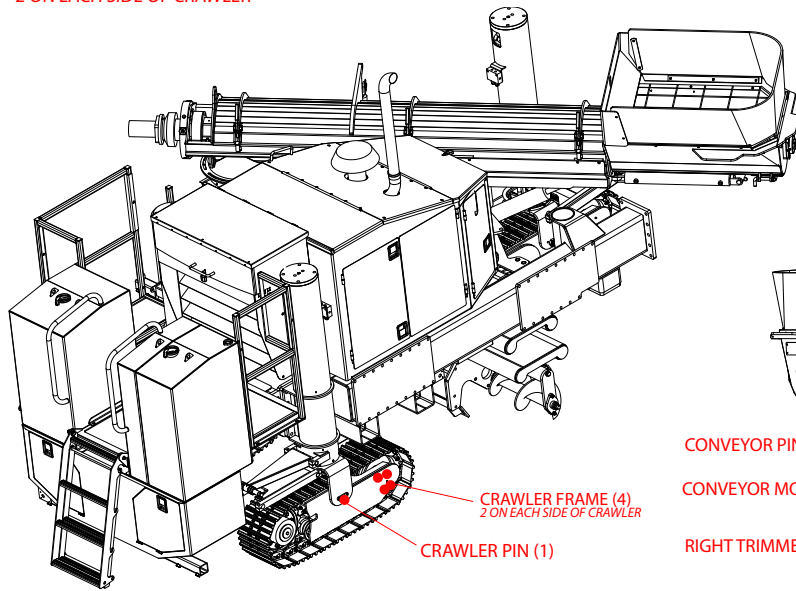

CRAWLER FRAME (4)
2 ON EACH SIDE OF CRAWLER

CRAWLER PIN (1)

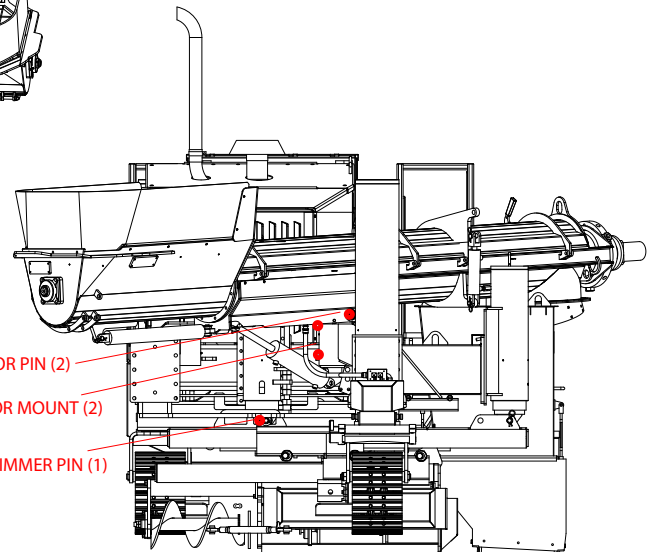

CONVEYOR PIN (2)

CONVEYOR MOUNT (2)

RIGHT TRIMMER PIN (1)

⚠ WARNING ⚠

You are responsible for the safe operation of this machine and for the safety of persons around the machine. Consult the appropriate Maintenance or Operations manuals or contact Power Curbers Product Support for assistance or questions.

Failure to maintain this machinery in strict accordance with the manufacturer's recommended practices may result in serious injury. Before performing any maintenance or repairs on the machine, perform the proper safety shutdown procedures to ensure that the machine is safe to work on.

Your safety and the safety of those around you depends on you using

care and judgment in operating and servicing this machine. Know the positions and functions of all controls and safety measures before attempting to operate and service the machine. Do not attempt a repair for which you are not qualified or properly trained.

If this machine is not operated and serviced in accordance with the Operations and Maintenance Manuals and the safety signs on the machine, the manufacturer and seller of this machine disclaim all express and implied warranties, including any warranty of merchantability, or fitness, or otherwise with respect to any claim for property damage or personal injury and expressly disclaim all remedies for such claims.

Power Curbers
Product Support
704.647.6141
www.powercurbers.com